



US009905160B2

(12) **United States Patent**
Woo et al.

(10) **Patent No.:** **US 9,905,160 B2**
(45) **Date of Patent:** **Feb. 27, 2018**

(54) **ORGANIC LIGHT EMITTING DIODE DISPLAY FOR SENSING ELECTRICAL CHARACTERISTIC OF DRIVING ELEMENT**

(71) Applicant: **LG DISPLAY CO., LTD.**, Seoul (KR)

(72) Inventors: **Kyoungdon Woo**, Paju-si (KR);
Myunggi Lim, Ansan-si (KR)

(73) Assignee: **LG DISPLAY CO., LTD.**, Seoul (KR)

(*) Notice: Subject to any disclaimer, the term of this patent is extended or adjusted under 35 U.S.C. 154(b) by 56 days.

(21) Appl. No.: **14/851,154**

(22) Filed: **Sep. 11, 2015**

(65) **Prior Publication Data**

US 2016/0078805 A1 Mar. 17, 2016

(30) **Foreign Application Priority Data**

Sep. 12, 2014 (KR) 10-2014-0121091

(51) **Int. Cl.**
G09G 3/3233 (2016.01)
G09G 3/3225 (2016.01)

(52) **U.S. Cl.**
CPC **G09G 3/3225** (2013.01); **G09G 3/3233** (2013.01); **G09G 2300/0842** (2013.01); **G09G 2320/0295** (2013.01); **G09G 2320/043** (2013.01); **G09G 2320/045** (2013.01)

(58) **Field of Classification Search**
CPC **G09G 3/3225**; **G09G 3/3233**; **G09G 2320/043**; **G09G 2320/0295**; **G09G 2300/0842**; **G09G 2320/045**; **G09G 2320/029**

See application file for complete search history.

(56) **References Cited**

U.S. PATENT DOCUMENTS

2006/0007206 A1 *	1/2006	Reddy	G06F 3/03542
				345/204
2009/0213049 A1 *	8/2009	McCreary	G09G 3/3233
				345/80
2010/0277400 A1 *	11/2010	Jeong	G09G 3/3275
				345/76
2011/0254871 A1 *	10/2011	Yoo	G09G 3/3233
				345/690

(Continued)

FOREIGN PATENT DOCUMENTS

CN	201639647 U	11/2010
CN	103854602 A	6/2014

OTHER PUBLICATIONS

Chinese Search Report First Office Action dated Aug. 2, 2017.

Primary Examiner — Darlene M Ritchie

(74) Attorney, Agent, or Firm — Dentons US LLP

(57) **ABSTRACT**

An organic light emitting diode display is disclosed. The organic light emitting diode display includes a display panel including a plurality of pixels, a plurality of sensing units configured to integrate current information of the pixels through a plurality of sensing channels connected to sensing lines of the display panel and output a first sensing value, a reference sensing unit configured to integrate previously set reference current information and output a reference sensing value, a calculation block configured to calculate the first sensing value and the reference sensing value, remove a common noise component from the first sensing value, and output a second sensing value, and an analog-to-digital converter configured to convert the second sensing value into a digital sensing value.

2 Claims, 8 Drawing Sheets

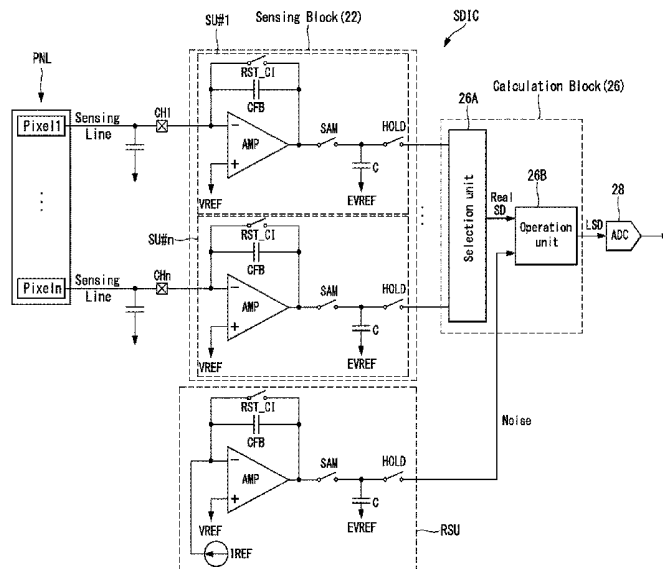

(56)

References Cited

U.S. PATENT DOCUMENTS

2011/0279444	A1 *	11/2011	Chung	G09G 3/3233 345/214
2013/0016091	A1 *	1/2013	Kato	G09G 3/3225 345/419
2013/0300690	A1	11/2013	Yang et al.	
2014/0009216	A1	1/2014	Jo et al.	
2014/0152642	A1 *	6/2014	Kim	G09G 3/3233 345/212
2014/0198092	A1 *	7/2014	Azizi	G09G 3/006 345/212
2014/0347332	A1 *	11/2014	Lee	G09G 3/3233 345/204
2015/0009204	A1 *	1/2015	Chaji	G09G 3/3233 345/214
2015/0048881	A1 *	2/2015	Kwon	H03H 19/004 327/554
2015/0077314	A1 *	3/2015	Kim	G09G 3/3233 345/76
2015/0138177	A1 *	5/2015	Kwon	G09G 3/3233 345/211
2016/0300534	A1 *	10/2016	Kishi	G09G 3/3233
2017/0104480	A1 *	4/2017	Eshel	H03K 5/1252

* cited by examiner

FIG. 1

(RELATED ART)

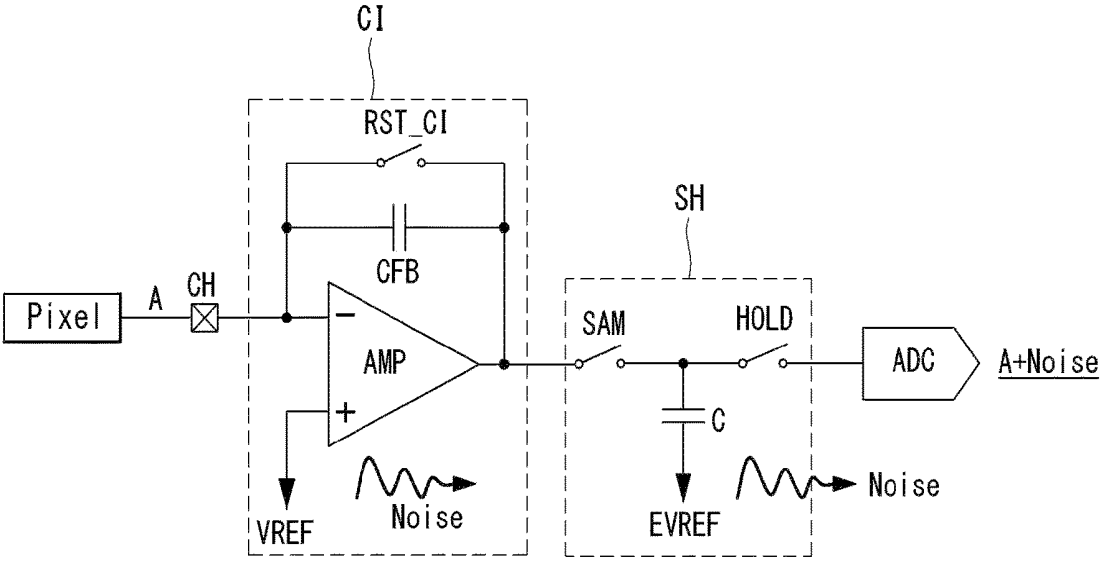

FIG. 2

(RELATED ART)

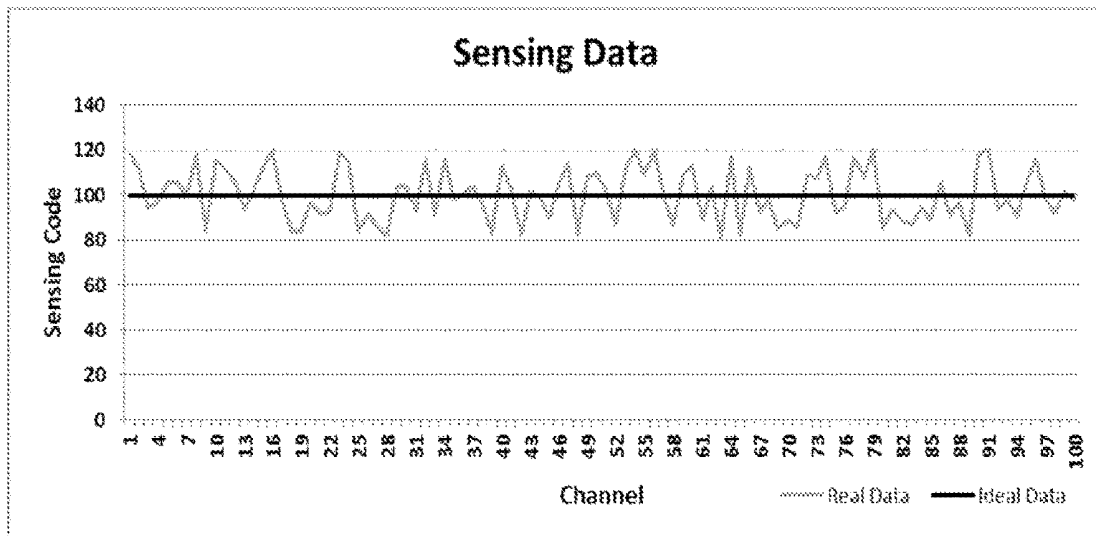

FIG. 3

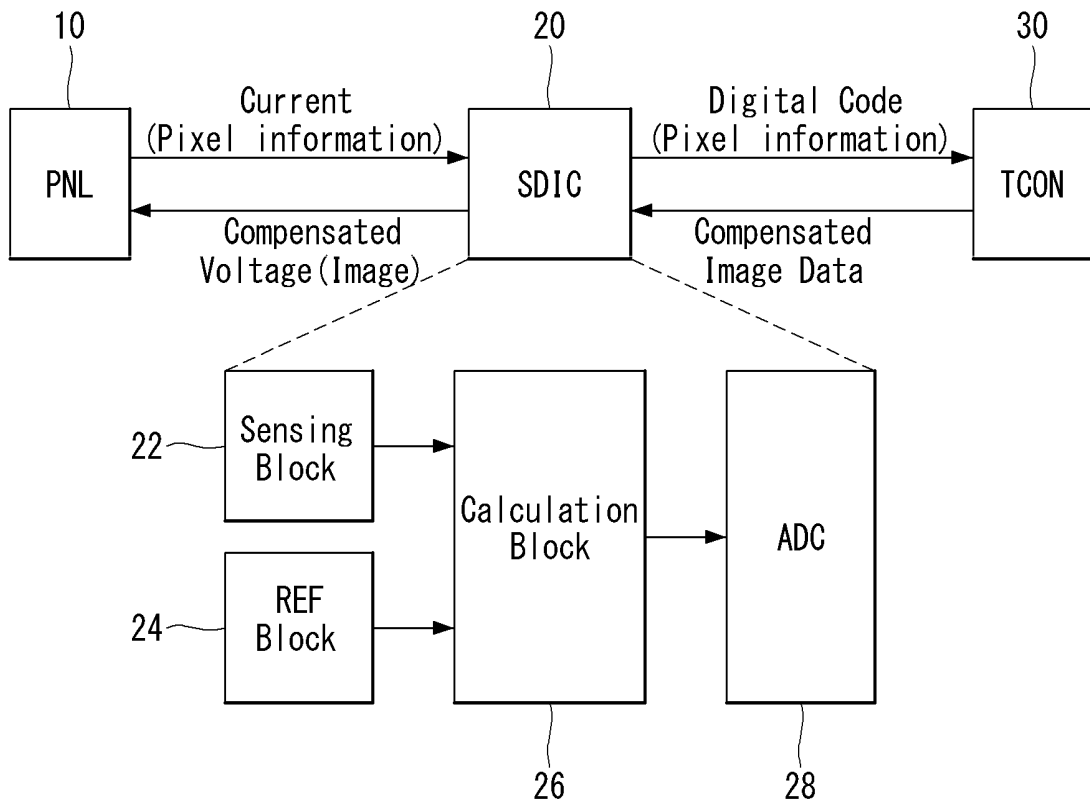

FIG. 4

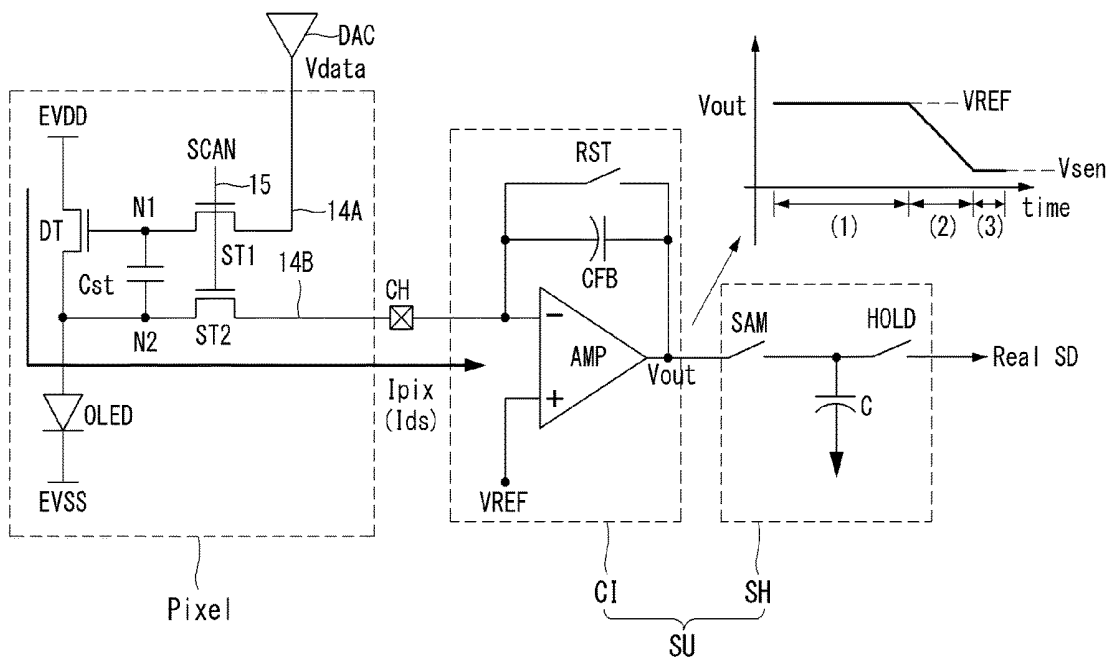

FIG. 5

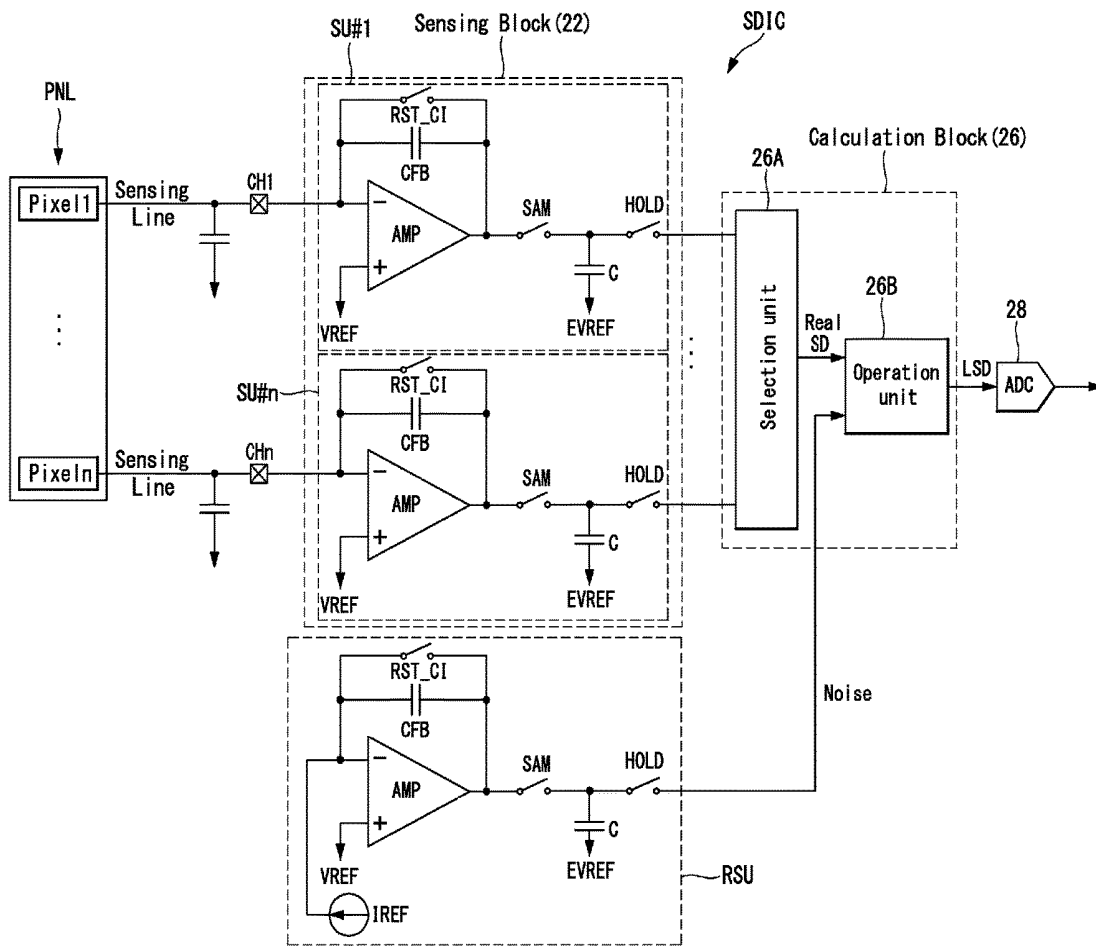

FIG. 6

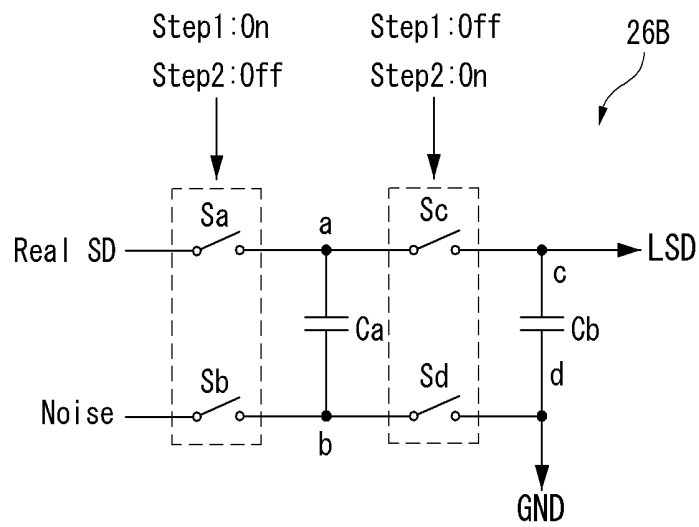

FIG. 7

Step	a	b	c	d
1	Real SD	Noise		GND
2			Real SD-(Noise-GND)	GND

FIG. 8

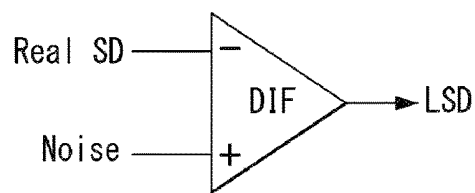

FIG. 9

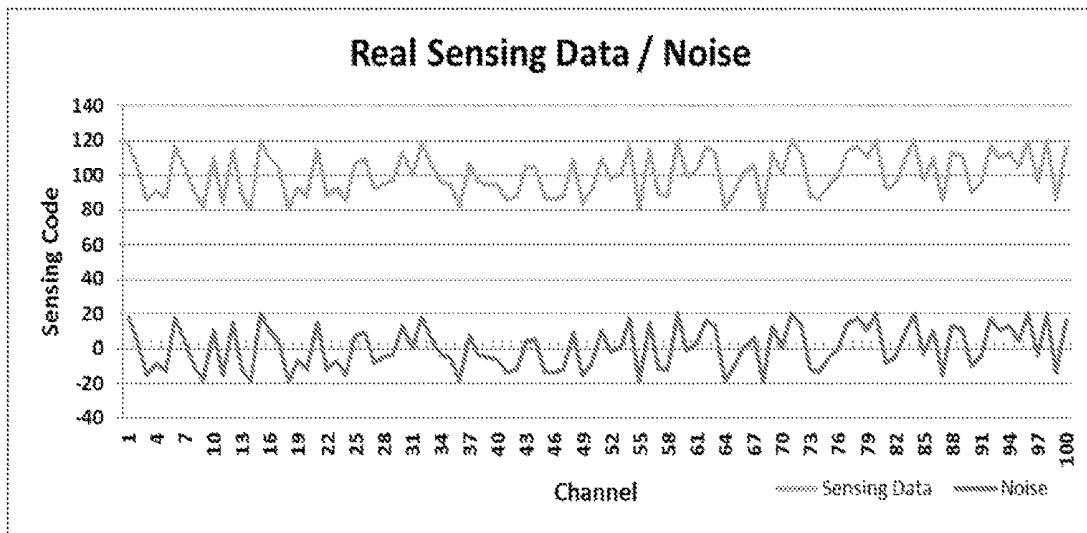
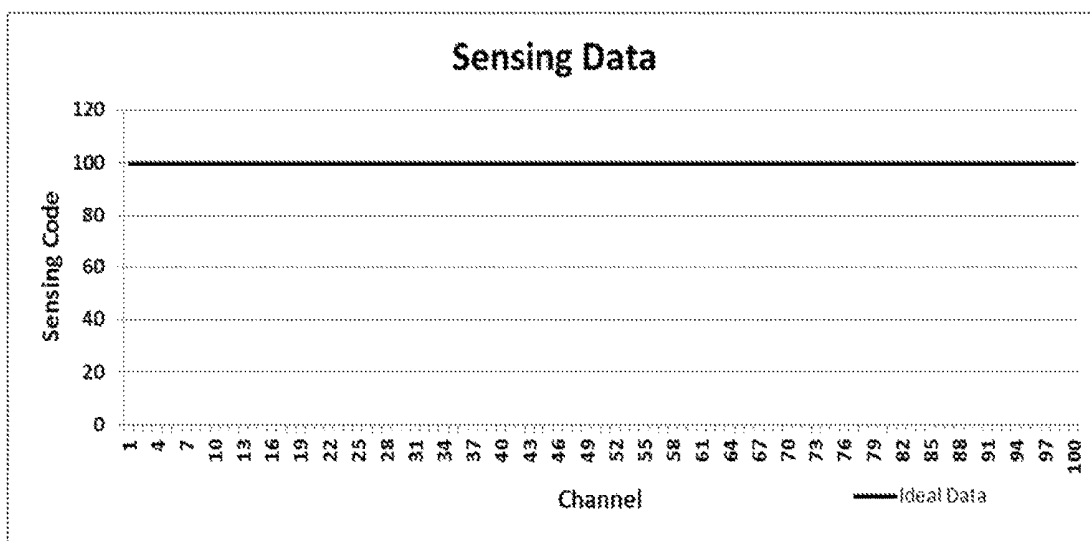

FIG. 10



second input terminal, to which the reference sensing value is input, and the second node, a third switch connected between the first node and the third node, and a fourth switch connected between the second node and the fourth node. The first and second switches maintain a turn-on state during a first period and maintain a turn-off state during a second period following the first period. The third and fourth switches maintain a turn-off state during the first period and maintain a turn-on state during the second period.

The operation unit is implemented as a differential amplifier.

The sensing units and the reference sensing unit are driven by the same external power source.

BRIEF DESCRIPTION OF THE DRAWINGS

The accompanying drawings, which are included to provide a further understanding of the invention and are incorporated in and constitute a part of this specification, illustrate embodiments of the invention and together with the description serve to explain the principles of the invention. In the drawings:

FIG. 1 shows a noise entering into a sensing unit of a current sensing method;

FIG. 2 shows a first sensing value, with which an external noise is mixed;

FIG. 3 is a block diagram schematically showing an organic light emitting diode display, sensing electrical characteristic of a driving element using a current sensing method, according to an exemplary embodiment of the invention;

FIG. 4 illustrates a connection structure and a sensing operation of a pixel and a sensing unit, for implementing a current sensing method, according to an exemplary embodiment of the invention;

FIG. 5 illustrates detailed configuration of a sensing block including a plurality of sensing units, detailed configuration of an REF block including a reference sensing unit, and detailed configuration of a calculation block removing a common noise component;

FIG. 6 shows an example of implementing an operation unit included in a calculation block;

FIG. 7 illustrates an operation of an operation unit shown in FIG. 6;

FIG. 8 shows another example of implementing an operation unit included in a calculation block;

FIG. 9 shows a first sensing value and a reference sensing value each including a common noise component; and

FIG. 10 shows a second sensing value, from which a common noise component is removed.

DETAILED DESCRIPTION OF THE ILLUSTRATED EMBODIMENTS

Reference will now be made in detail to embodiments of the invention, examples of which are illustrated in the accompanying drawings. Wherever possible, the same reference numbers will be used throughout the drawings to refer to the same or like parts. It will be paid attention that detailed description of known arts will be omitted if it is determined that the arts can mislead the embodiments of the invention.

FIG. 3 is a block diagram schematically showing an organic light emitting diode display, sensing electrical characteristics of a driving element using a current sensing method, according to an exemplary embodiment of the invention. FIG. 4 illustrates a connection structure and a

sensing operation of a pixel and a sensing unit, for implementing a current sensing method, according to an exemplary embodiment of the invention.

Referring to FIGS. 3 and 4, the organic light emitting diode display according to the embodiment of the invention includes a display panel 10 (denoted by "PNL"), a source driver integrated circuit (IC) 20 (denoted by "SDIC"), and a timing controller 30 (denoted by "TCON").

A plurality of data and sensing lines 14A and 14B and a plurality of gate lines 15 cross each other on the display panel 10, and pixels are respectively disposed at crossings of the lines 14A, 14B, and 15 in a matrix form.

Each pixel is connected to one of the data lines 14A, one of the sensing lines 14B, and one of the gate lines 15. Each pixel receives a sensing data voltage from the data line 14A in response to a gate pulse input through the gate line 15 and outputs a sensing signal through the sensing line 14B.

Each pixel receives a high potential driving voltage EVDD and a low potential driving voltage EVSS from a power generator (not shown). Each pixel may include an organic light emitting diode (OLED), a driving thin film transistor (TFT) DT, first and second switching TFTs ST1 and ST2, and a storage capacitor Cst. The TFTs constituting the pixel may be implemented as a p-type TFT or an n-type TFT. A semiconductor layer of the TFT constituting the pixel may include amorphous silicon, polysilicon, or oxide.

The source driver IC 20 includes components required to sense a current and senses current information I_{pix} from the pixels of the display panel 10. The source driver IC 20 includes a sensing block 22 including a plurality of sensing units SU and an analog-to-digital converter (ADC) 28 to output a sensing value. Further, the source driver IC 20 further includes an REF block 24 and a calculation block 26, so as to remove a noise component included in the sensing value.

The REF block 24 includes a reference sensing unit using the same external power source as the sensing units SU of the sensing block 22. Because the reference sensing unit and the sensing unit SU are driven by the same external power source, a common noise component is included in sensing values of the reference sensing unit and the sensing unit SU. The calculation block 26 functions to remove the common noise component.

The sensing unit SU of the sensing block 22 includes a current integrator CI and a sample and hold unit SH. The current I_{pix} flowing in the pixel is applied to the current integrator CI through the sensing line 14B and is changed into a voltage through an integration process of the current integrator CI. The voltage changed from the current passes through the sample and hold unit SH and is applied to the calculation block 26 as a first sensing value. The reference sensing unit of the REF block 24 uses the same external power source as the sensing units SU of the sensing block 22, integrates previously set reference current information, and applies the result of an integration to the calculation block 26 as a reference sensing value. The calculation block 26 calculates the first sensing value from the sensing block 22 and the reference sensing value from the REF block 24 and removes the common noise component from the first sensing value, thereby outputting a second sensing value. The ADC 28 converts the second sensing value into a digital sensing value.

The timing controller 30 obtains compensation data for compensating for changes in a threshold voltage and a mobility of the driving TFT DT based on the digital sensing value from the source driver IC 20 and modulates image data based on the compensation data. The timing controller 30

then transmits the modulated image data to the source driver IC 20. The modulated image data is converted into an image display data voltage by a digital-to-analog converter (DAC) of the source driver IC 20 and then may be applied to the display panel 10.

A connection structure of one pixel and one sensing unit, for implementing the current sensing method, according to the embodiment of the invention is shown in FIG. 4. Referring to FIG. 4, the pixel may include the OLED, the driving TFT DT, the first and second switching TFTs ST1 and ST2, and the storage capacitor Cst.

The OLED includes an anode electrode connected to a second node N2, a cathode electrode connected to an input terminal of the low potential driving voltage EVSS, and an organic compound layer formed between the anode electrode and the cathode electrode. The driving TFT DT controls an amount of current input to the OLED based on a gate-to-source voltage V_{gs} of the driving TFT DT. The driving TFT DT includes a gate electrode connected to a first node N1, a drain electrode connected to an input terminal of the high potential driving voltage EVDD, and a source electrode connected to the second node N2. The storage capacitor Cst is connected between the first node N1 and the second node N2. The first switching TFT ST1 is turned on in response to a gate pulse SCAN and applies a data voltage Vdata on the data line 14A to the first node N1. The first switching TFT ST1 includes a gate electrode connected to the gate line 15, a drain electrode connected to the data line 14A, and a source electrode connected to the first node N1. The second switching TFT ST2 switches on or off a current flow between the second node N2 and the sensing line 14B in response to the gate pulse SCAN. The second switching TFT ST2 includes a gate electrode connected to the gate line 15, a drain electrode connected to the sensing line 14B, and a source electrode connected to the second node N2.

As shown in FIG. 4, the current integrator CI includes an amplifier AMP including an inverting input terminal (-) receiving the pixel current I_{pix} (i.e., a source-to-drain current I_{ds} of the driving TFT DT) from the sensing line 14B through a sensing channel CH, a non-inverting input terminal (+) receiving a reference voltage VREF, and an output terminal, an integrating capacitor CFB connected between the inverting input terminal (-) and the output terminal of the amplifier AMP, and a reset switch RST connected to both terminals of the integrating capacitor CFB.

The sample and hold unit SH is connected to an output terminal of the current integrator CI. The sample and hold unit SH includes a sampling switch SAM for sampling an integration value V_{sen} of the current integrator CI, a sampling capacitor C storing the integration value V_{sen} applied through the sampling switch SAM, and a holding switch HOLD outputting the integration value V_{sen} stored in the sampling capacitor C as the first sensing value.

An operation of the current integrator CI may be dividedly described in an initialization period (1), a sensing period (2), and a sampling period (3).

In the initialization period (1), the amplifier AMP operates as a unit gain buffer of a gain "1" due to a turn-on of the reset switch RST. Further, all of the input terminals (+) and (-) and the output terminal of the amplifier AMP, the sensing line 14B, and the second node N2 are initialized to the reference voltage VREF.

In the initialization period (1), the sensing data voltage Vdata is applied to the first node N1 through the DAC of the source driver IC 20. Hence, the source-to-drain current I_{ds} corresponding to a voltage difference ($=V_{data}-V_{REF}$) between the first node N1 and the second node N2 flows in

the driving TFT DT, thereby stabilizing the driving TFT DT. However, because the amplifier AMP continuously operates as the unit gain buffer during the initialization period (1), a voltage of the output terminal of the amplifier AMP is held at the reference voltage VREF.

In the sensing period (2), the amplifier AMP operates as the current integrator CI due to a turn-off of the reset switch RST, and the source-to-drain current I_{ds} flowing in the driving TFT DT is stored in the integrating capacitor CFB through an integration operation. In the sensing period (2), a voltage difference between both terminals of the integrating capacitor CFB increases due to the source-to-drain current I_{ds} entering into the inverting input terminal (-) of the amplifier AMP, as a sensing time passed (i.e., as an accumulation amount of source-to-drain current I_{ds} increases). However, the inverting input terminal (-) and the non-inverting input terminal (+) of the amplifier AMP are shorted through a virtual ground due to characteristic of the amplifier AMP, and a voltage difference between the inverting input terminal (-) and the non-inverting input terminal (+) of the amplifier AMP is zero. Therefore, a voltage of the inverting input terminal (-) is held at the reference voltage VREF in the sensing period (2), irrespective of an increase in the voltage difference between both terminals of the integrating capacitor CFB. Instead, a voltage of the output terminal of the amplifier AMP decreases correspondingly to an increase in the voltage difference between both terminals of the integrating capacitor CFB. By such a principle, the source-to-drain current I_{ds} entering through the sensing line 14B in the sensing period (2) is changed into an output value V_{out} expressed as voltage through the integrating capacitor CFB. A falling slope of the output value V_{out} increases as an amount of the source-to-drain current I_{ds} entering through the sensing line 14B increases. Therefore, as the amount of the source-to-drain current I_{ds} increases, the integration value V_{sen} decreases. In the sensing period (2), the integration value V_{sen} is stored in the sampling capacitor C via the sampling switch SAM.

In the sampling period (3), when the holding switch HOLD is turned on, the integration value V_{sen} stored in the sampling capacitor C is output as the first sensing value via the holding switch HOLD.

FIG. 5 illustrates a detailed configuration of a sensing block 22 including a plurality of sensing units, a detailed configuration of an REF block including a reference sensing unit, and a detailed configuration of a calculation block 26 removing a common noise component. FIG. 6 shows an example of implementing an operation unit included in a calculation block. FIG. 7 illustrates an operation of an operation unit shown in FIG. 6. FIG. 8 shows another example of implementing an operation unit included in a calculation block.

Referring to FIG. 5, a plurality of sensing units SU#1 to SU#n are connected to the pixels through sensing channels CH1 to CHn and the sensing lines 14B and sense pixel current information. A connection structure and an operation of the sensing units SU#1 to SU#n are substantially the same as those described in FIG. 4.

A reference sensing unit RSU of the REF block 24 is connected to a reference current source IREF and senses reference current information. For this, the reference sensing unit RSU includes a current integrator and a sample and hold unit in the same manner as the sensing units SU#1 to SU#n. An inverting input terminal (-) of the current integrator included in the reference sensing unit RSU is connected to the reference current source IREF.

It is preferable, but not required, that the reference sensing unit RSU is designed so that the reference sensing unit RSU is affected by the same noise as the sensing units SU#1 to SU#n so as to easily remove the noise. For this, the current integrator of the reference sensing unit RSU is designed so that it receives the same external power source VREF as the current integrators of the sensing units SU#1 to SU#n. Further, the sample and hold unit of the reference sensing unit RSU may receive the same external power source EVREF as the sample and hold units of the sensing units SU#1 to SU#n.

Because the reference sensing unit RSU and the sensing units SU#1 to SU#n share the external power source with each other, a first sensing value Real SD of the sensing unit SU and the reference sensing value of the reference sensing unit RSU include the same noise component (i.e., the common noise component). The common noise component is removed by the calculation block 26. When a reference current value of the reference current source IREF is properly designed, only the noise component may be included in the reference sensing value output from the reference sensing unit RSU. In this instance, the operation of the calculation block 26 becomes simple.

The calculation block 26 may include a selection unit 26A sequentially outputting the first sensing values Real SD input from the sensing units SU#1 to SU#n and an operation unit 26B subtracting the reference sensing value from the first sensing value Real SD input from the selection unit 26A.

As shown in FIG. 6, the operation unit 26B may include four switches Sa, Sb, Sc, and Sd and two capacitors Ca and Cb.

More specifically, the operation unit 26B may include the first capacitor Ca connected between a first node 'a' and a second node 'b', the second capacitor Cb connected between a third node 'c' connected to the ADC 28 and a fourth node 'd' connected to a ground level voltage source GND, the first switch Sa connected between a first input terminal, to which the first sensing values Real SD are input, and the first node 'a', the second switch Sb connected between a second input terminal, to which the reference sensing value is input, and the second node 'b', the third switch Sc connected between the first node 'a' and the third node 'c', and the fourth switch Sd connected between the second node 'b' and the fourth node 'd'.

The first and second switches Sa and Sb maintain a turn-on state during a first period Step1 and maintain a turn-off state during a second period Step2 following the first period Step 1. On the contrary, the third and fourth switches Sc and Sd maintain a turn-off state during the first period Step1 and maintain a turn-on state during the second period Step2.

As shown in FIG. 7, during the first period Step1, the first sensing value Real SD including the common noise component is applied to the first node 'a', and the reference sensing value including the common noise component is applied to the second node 'b'. During the second period Step2, the first node 'a' and the third node 'c' are shorted, and the second node 'b' and the fourth node 'd' are shorted. The reference sensing value stored in the second node 'b' is reduced to a ground value in the second period Step2, and thus the first sensing value Real SD of the third node 'c' is reduced to the voltage of the second node 'b' in the second period Step2. As a result, the common noise component is removed from the first sensing value Real SD.

As shown in FIG. 8, the operation unit 26B may be implemented as a differential amplifier differentially ampli-

fy the first sensing value Real SD input from a first input terminal (-) and the reference sensing value input from a second input terminal (+).

As shown in FIG. 9, the operation unit 26B receives the first sensing value and the reference sensing value each including the common noise component. As shown in FIG. 10, the operation unit 26B outputs the second sensing value, from which the common noise component is removed.

Although embodiments have been described with reference to a number of illustrative embodiments thereof, it should be understood that numerous other modifications and embodiments can be devised by those skilled in the art that will fall within the scope of the principles of this disclosure. More particularly, various variations and modifications are possible in the component parts and/or arrangements of the subject combination arrangement within the scope of the disclosure, the drawings and the appended claims. In addition to variations and modifications in the component parts and/or arrangements, alternative uses will also be apparent to those skilled in the art.

What is claimed is:

1. An organic light emitting diode display comprising:

a display panel including a plurality of pixels;

a plurality of sensing units, each of which includes a current integrator and a sample and hold unit, that integrate current information of the pixels through a plurality of sensing channels connected to sensing lines of the display panel and output a first sensing value;

a reference sensing unit that is separate and distinct from the plurality of sensing units and includes a current integrator electrically connected to a previously set reference current source and a first same external power source applied to each current integrator of the plurality of sensing units and a sample and hold unit electrically connected to a second same external power source applied to each sample and hold unit of the plurality of sensing units, wherein the reference sensing unit senses reference current information and outputs a reference sensing value;

a calculation block that calculates the first sensing value and the reference sensing value, removes a common noise component from the first sensing value, and outputs a second sensing value; and

an analog-to-digital converter that converts the second sensing value into a digital sensing value,

wherein the calculation block includes an operation circuit that subtracts the reference sensing value from the first sensing value input sequentially from the plurality of sensing units,

wherein the operation circuit includes:

a first capacitor connected between a first node and a second node;

a second capacitor connected between a third node connected to the analog-to-digital converter and a fourth node connected to a ground level voltage source;

a third switch connected between the first node and the third node; and

a fourth switch connected between the second node and the fourth node.

2. The organic light emitting diode display of claim 1, wherein the operation circuit further includes:

a first switch connected between a first input terminal, to which the first sensing values are input, and the first node; and

a second switch connected between a second input terminal, to which the reference sensing value is input, and the second node,

wherein the first and second switches maintain a turn-on state during a first period and maintain a turn-off state during a second period following the first period, and wherein the third and fourth switches maintain a turn-off state during the first period and maintain a turn-on state 5 during the second period.

* * * * *

专利名称(译)	用于感测驱动元件的电特性的有机发光二极管显示器		
公开(公告)号	US9905160	公开(公告)日	2018-02-27
申请号	US14/851154	申请日	2015-09-11
[标]申请(专利权)人(译)	乐金显示有限公司		
申请(专利权)人(译)	LG DISPLAY CO., LTD.		
当前申请(专利权)人(译)	LG DISPLAY CO., LTD.		
[标]发明人	WOO KYOUNGDON LIM MYUNGGI		
发明人	WOO, KYOUNGDON LIM, MYUNGGI		
IPC分类号	G09G3/3233 G09G3/3225		
CPC分类号	G09G3/3225 G09G3/3233 G09G2320/045 G09G2320/0295 G09G2320/043 G09G2300/0842 G09G3/30 G09G3/32		
代理机构(译)	DENTONS美国律师事务所		
优先权	1020140121091 2014-09-12 KR		
其他公开文献	US20160078805A1		
外部链接	Espacenet USPTO		

摘要(译)

公开了一种有机发光二极管显示器。有机发光二极管显示器包括：显示面板，包括多个像素；多个感测单元，被配置为通过连接到显示面板的感测线的多个感测通道来集成像素的电流信息并输出第一感测值，参考感测单元，被配置为整合先前设置的参考电流信息并输出参考感测值，计算块被配置为计算第一感测值和参考感测值，从第一感测值移除公共噪声分量，并输出第二感测值感测值和模数转换器，被配置为将第二感测值转换为数字感测值。

